

Ref. No.: NIT-ANDHRA/ESTATE/EE/S, I - DINING TABLES/2020(RE-TENDER) DATE:28.01.2020

**(Notice Inviting Re-Tender)**

(Box Tenders/Open Tenders)

**(FOR SUPPLY & INSTALLATION OF DINING TABLES CONTRACT AT NIT ANDHRA  
PRADESH, TADEPALLIGUDEM)**



**NATIONAL INSTITUTE OF TECHNOLOGY ANDHRA PRADESH  
TADEPALLIGUDEM**

Near National Highway No. 16, Kondrupolu,  
TADEPALLIGUDEM – 534101 West Godavari District, Andhra Pradesh

**Proprietary & Confidential:**

No part of this document can be reproduced in any form or by any means, disclosed or distributed to any person without the prior consent of the Director, NIT Andhra Pradesh, Tadepalligudem, except to the extent required for submitting bid and no more.

**Contents:**

| <b>Description</b>                                | <b>Page No.</b> |
|---|-----------------|
| NEWSPAPER ADVERTISEMENT                           | 3               |
| TIME SCHEDULE                                     | 4               |
| BID   | 6               |
| STATEMENT RELATED TO BIDS                         | 7               |
| TENDER SCHEDULE                                   | 8               |
| TENDER PROCESSING FEE, EMD, PERFORMANCE GUARANTEE | 8               |
| ELIGIBILITY CRITERIA                              | 9               |
| METHOD OF SUBMISSION OF BIDS                      | 10              |
| EVALUATION PROCEDURE                              | 10              |
| GENERAL TERMS AND CONDITIONS                      | 12              |
| SCOPE OF SUPPLY                                   | 13              |
| SPECIFICATIONS                                    | 13              |
| SERVICE TERMS AND CONDITIONS                      | 13              |
| SUPPLY AND PAYMENT SCHEDULE                       | 14              |
| TECHNICAL BID                                     | 16              |
| FINANCIAL BID                                     | 20              |
| DECLARATION                                       | 22              |

## Newspaper Advertisement

**Tender Notice:**



**NIT Andhra Pradesh, Tadepalligudem**

**Ref. No.: NIT-ANDHRA/ESTATE/EE/S, I - DINING TABLES/2020(RE-TENDER)**

**Box Tenders/Open Tenders are hereby invited from reputed Registered Firms/Agencies/Contractors/Suppliers** for providing the following services at NIT Andhra Pradesh, Tadepalligudem, West Godavari district.

**“Supply & Installation of Dining tables at Student messes of NIT Andhra Pradesh, Tadepalligudem”**

Tender Schedules can be downloaded from NIT Andhra Pradesh website from 28.01.2020 onwards. Bidders need to submit hard copy with relevant documents attested by gazetted officer.

**The last date for submission of tenders is 26.02.2020 up to 11:00AM.**

For further details regarding Tender notification & specifications, please visit [www.nitandhra.ac.in](http://www.nitandhra.ac.in).

**Date: 28.01.2020  
NIT Andhra Pradesh,  
Tadepalligudem.**

**Time Schedule of various tender related events**

**(for Supply & Installation of Dining tables at Student messes of NIT Andhra Pradesh, Tadepalligudem)**

|   |  |
|---|--|
| Bid Document downloading<br>Start date/ Time  | 28.01.2020 at 10.00am  |
| Bid Document downloading<br>End Date/ Time    | 25.02.2020 at 01.00pm  |
| Last Date and Time for the<br>receipt of Bids | 26.02.2020 at 11.00 am   |
| Technical Bid<br>Opening Date /Time           | 26.02.2020 at 03.00pm  |
| Financial Bid<br>Opening Date / Time          | Will be intimated later  |
| Contact Person                                | The Registrar, NIT Andhra Pradesh, Tadepalligudem.               |
| Reference No:                                 | <b>NIT-ANDHRA/ESTATE/EE/S, I - DINING TABLES/2020(RE-TENDER)</b> |

Signature of the Bidder with stamp

### CLARIFICATIONS

Queries, if any, can be made through e-mail only to **registrar@nitandhra.ac.in** on or before 25.02.2020. Queries received via any mode other than e-mail id mentioned above shall not be entertained. The queries should only be sent in the following format on the official letter head of the company.

| S. No. | Page No.<br>(Tender Ref.) | Clause<br>(Tender Ref.) | Description<br>(Tender Ref.) | Query |
|--------|---------------------------|-------------------------|------------------------------|-------|
|        |                           |                         |                              |       |

If there is any addendum/corrigendum related to tender, it shall only be published on NIT Andhra Pradesh website ([www.nitandhra.ac.in](http://www.nitandhra.ac.in)). The Bidders are advised to check NIT Andhra Pradesh website regularly. No other mode of notice will be given.

The Bidders are requested to submit the bids after issue of clarifications duly considering the changes made, if any. Bidders are totally responsible for incorporating/complying the changes/ amendments issued, if any, during pre-bid meeting in their bid.

If the last date of receiving/opening of the bids coincides with a holiday, then the next working day shall be the receiving/opening date.

**The Technical Bid along with relevant documents should be attached with original EMD and Tender processing fee. Physical submission of Price bid only shall be considered.**

-Sd/-

**I/C REGISTRAR  
NIT ANDHRA PRADESH**

For any clarification and further details on the above tender, please contact.

Office Phone Number:08818-284710

**BID**

**Ref. No.: NIT-ANDHRA/ESTATE/EE/S, I - DINING TABLES/2020(RE-TENDER) DATE:28.01.2020**

**Subject:** Tender for “Supply & Installation of Dining tables at Student messes of NIT Andhra Pradesh, Tadepalligudem”.

Sir/Madam,

Bids are invited on the Box/Open Tender platform from the reputed Registered Firms Agencies/Contractors/Suppliers from the experienced premises of dining tables supply & installation business. The details of bidding conditions and other terms can be downloaded from the NIT Andhra Pradesh Website.

The attested copies of all the documents of Technical bid, signed undertaking of Bidder should be submitted offline mode only to the Director, NIT Andhra Pradesh, Tadepalligudem, on or before opening of bid.

The participating Bidder/s shall have to pay tender processing fee (non-refundable) and EMD for the amounts specified in the Statement related to bids, in the form of DD drawn in favour of the Director, NIT Andhra Pradesh, Tadepalligudem.

Further, the Successful Bidder shall furnish a part of a bid as Performance Guarantee specified in the Statement related to bids, to be paid in the form of BG as mentioned in the Tender Schedule.

NIT Andhra Pradesh, Tadepalligudem, will not accept the tenders from blacklisted companies or undependable suppliers, whose past performance with NIT Andhra Pradesh was found poor due to delayed and/or erratic supplies and those with frequent product failures, and also against whom there have been adverse reports of sub-standard quality/poor services, as defined in the other parts of the bidding documents.

For any clarification and further details of the above tender, please contact.

Office Phone Number:08818-284710

Signature of the Bidder with stamp

**STATEMENT RELATED TO BIDS**

|  |   |
|--|---|
| Bid Document Fee/ Tender processing Fee (Non-refundable) | Rs. 10,000/- by way of DD from any Nationalized bank drawn in favor of the Director NIT Andhra Pradesh, Payable at Tadepalligudem.  |
| EMD  | Rs. 1,20,000/- (Rupees one lakh twenty thousand Only) by way of DD from any Nationalized bank drawn in favor of the Director NIT Andhra Pradesh, Payable at Tadepalligudem. |
| Estimated Contract Value                                 | Rs. 80,00,000/- (Rupees Eighty lakhs only)  |
| Bid Validity Period                                      | 90 days from the date of opening of Financial bid   |
| EMD Validity Period                                      | 90 days from the date of opening of Financial bid   |
| Period of furnishing Performance Guarantee               | Within 7 days from date of receipt of LOA   |
| Performance Guarantee Value                              | 5% on the work order value (in the form of BG)  |
| Performance Guarantee Validity Period                    | 1 year from the date of commencement of services  |
| Period for signing the order of acceptance               | Within 7 days from date of receipt of LOA   |

Signature of the Bidder with stamp

## TENDER SCHEDULE

### **PREMEABLE:**

National Institute of Technology, Andhra Pradesh, is the 31<sup>st</sup> NIT among the chain of NITs started by the Government of India. NIT Andhra Pradesh is established in the state of Andhra Pradesh in the academic year 2015 – 2016.

### **SUBJECT:**

Supply & Installation of Dining tables at Student messes of NIT Andhra Pradesh, Tadepalligudem.

### **TENDER DETAILS:**

#### **1. OVERVIEW:**

- a. NIT Andhra Pradesh is desirous of hiring a contractor for the said purpose subjected above.
- b. Bids are invited from eligible Bidders directly based on the eligibility criteria and general terms and conditions mentioned below. Interested Bidders may download the copy of the document(s) from website, i.e. [www.nitandhra.ac.in](http://www.nitandhra.ac.in).
- c. Interested Bidders are required to pay a Tender processing fee of Rs. 10,000/- (Rupees ten thousand only) and Earnest Money Deposit (EMD) of Rs.1,20,000/- (Rupees one lakh twenty thousand only) as prescribed in the Statement related to bids.
- d. Tender processing fee and EMD must be attached to the Technical Bid only and **NOT** to the Financial Bid.
- e. Bids received without EMD and Tender processing fee shall be summarily rejected.
- f. The Successful Bidder shall furnish a Performance Guarantee of an amount equivalent to 5% on work order value, in the form of bank guarantee from any Nationalized bank. Also, the Bank Guarantee shall be returned only after completion of warranty period and a satisfactory report obtained from Competent authority of NIT Andhra Pradesh.
- g. EMD of Bidder shall be forfeited, if the Bidder withdraws or amends its bid or impairs or derogated from the bid in any respect within the period of validity of its bid. Further, if the successful Bidder fails to furnish the Performance Guarantee within the specified period, his EMD shall be forfeited.
- h. In case the Bidders / Successful Bidder(s) are found in breach of any condition(s) at any stage of the tender, EMD / Performance Guarantee shall be forfeited.
- i. EMD will be returned to both Successful and Unsuccessful Bidders without any interest whatsoever, after allotment of Letter of Award.
- j. The return of EMD to the contractor (successful Bidder) shall be released only after the receipt of Performance Guarantee.



## **2. TERMINOLOGY:**

Definitions – Throughout this RFP/NIT, unless inconsistent with the subject matter or context:

- a. **Supplier/ Contractor/ Vendor** – Selected Bidder under this **RFP/NIT**.
- b. **Company/ Purchaser/ NIT Andhra Pradesh** - Reference to the “NIT Andhra Pradesh”, “Company” and “Purchaser” shall be determined in same context and referred as “NIT Andhra Pradesh, Tadepalligudem”.
- c. **Proposal/ Bid** – the Bidder’s written reply or submission in response to this **RFP/NIT**
- d. **RFP/NIT** – the request for proposal (NIT - this document) in its entirety, inclusive of any addenda that may be issued by NIT Andhra Pradesh, Tadepalligudem.

## **3. ELIGIBILITY CRITERIA:**

Following eligibility criteria required to be fulfilled by the tenderer (Copies of following documents to be submitted):

- a) **Work Experience:** The Bidders having experience of successfully completed similar nature of works in any Central/ State autonomous bodies and in any private organization during the last 2 years ending last day of the month previous to the one in which applications are invited. The works completed up to previous day of last date of submission of tenders shall also be considered.
  - Three similar works, each costing not less than the amount equal to 40% of estimated cost put to tenders.
  - Two similar works, each costing not less than the amount equal to 50% of estimated cost put to tenders.
  - One similar work of aggregate cost not less than the amount equal to 80% of estimated cost put to tenders.
- b) **Annual Financial Turnover:** Should have had average annual financial turnover of at least One crore during the last two years from the overall business ending March 31, 2019.
- c) Registration of GST
- d) Copy of Registration of firm
- e) PAN (Permanent Account Number)
- f) Latest IT returns for the FY 17-18 & 18-19
- g) Self-declaration, declaring Bidder has not been blacklisted by a Central/ State / Local Government Organization/ Academic Institution /PSU as per Annexure-III

#### **4. METHOD OF SUBMISSION OF BIDS:**

- The bids should be filled in two bid formats with all the required documents as enclosures in separate sealed covers i.e. (a) Part-I Technical bid, (b) Part-II Financial bid
- Two separate sealed covers should be specifically super-scribed as **(a) "Technical bid for Supply & Installation of Dining tables at student messes of NIT Andhra Pradesh, Tadepalligudem"** and **(b) "Financial bid for Supply & Installation of Dining tables at student messes of NIT Andhra Pradesh, Tadepalligudem"**. Both the sealed envelopes (a) and (b) are to be kept in another Master envelope, which should also be sealed and submitted.
- The Master envelope should be super-scribed with **"Tender for Supply & Installation of Dining tables at student messes of NIT Andhra Pradesh, Tadepalligudem"** and shall be addressed to The Tender Box, C/o Director, National Institute of Technology Andhra Pradesh, Near National Highway No. 16, Kondruprolu, West Godavari District, Andhra Pradesh, A.P-534101.
- **Last date for submission of bid documents is 26.02.2020 up to 11.00 a.m.**
- Bids received after the due date and time shall be summarily rejected.
- Incomplete bids or bids not submitted in prescribed format are liable for rejection.

#### **5. EVALUATION PROCEDURE:**

- At the first stage, the Technical Bids shall be opened in the presence of Bidders, who may like to be present on 26.02.2020 at 03.00 p.m in Administrative section, NIT Andhra Pradesh, Tadepalligudem, Near National Highway No. 16, Kondruprolu, TADEPALLIGUDEM – 534101 West Godavari District, Andhra Pradesh
- A Committee duly constituted by the Competent Authority would evaluate the Technical bids submitted by the Bidders.
- Prior to detailed evaluation, the Institute will determine the substantial responsiveness of each bid to the tender document. A substantially responsive bid is one which conforms to all the terms and conditions of the bidding/tender document and is without any material defects and deviations. Deviations from, or objections or reservations to critical provisions such as those concerning qualification/eligibility criteria, availability of facilities and amenities as needed, availability of government/statutory approvals and clearances, ready and explicit willingness to accept and honour the terms and conditions of contract etc. will be deemed to be material deviations.
- If a bid is not substantially responsive, it will be rejected by the Institute and may not subsequently be made responsive by the Bidder by correction of the non-conformity.
- Only those Bidders whose technical bids have been found to be substantially responsive would be evaluated.
- The Financial bids of those Bidders only shall be opened who qualified in the Technical Evaluation. The Institute will award the contract to the Successful Bidder, whose Financial bid is the lowest price bid among all the quoted bids. The decision of the Director, NIT Andhra Pradesh, Tadepalligudem, is final in this regard.
- Tenders with revised/modified rates/offer after opening of the tenders shall be summarily rejected and the entire Earnest Money Deposit (EMD) submitted with the tender shall be forfeited

- The tender is not transferable under any circumstances.
- Telegraphic, conditional or incomplete tenders shall not be accepted. Canvassing of any kind, direct or indirect, shall lead to disqualification of the Bidder.
- Institute reserves the right to reject any or all the tenders at any stage or accept them in part or reject the lowest tender without assigning any reason thereof and the decision of the Institute in this respect shall be final.
- The Institute reserves the right to cancel the tender process at any stage without assigning any reason.

For further details, please contact the NIT Andhra Pradesh Administration on 08818-284710.

**TIE BREAKING PROCEDURE:**

1. The Total Amount quoted in Rupees in the Financial bid for all the categories, shall be the first criteria for deciding the lowest Bidder.
2. In case of a tie in the least quoted price, the following tie-breaking procedure shall be applicable. The contract will be awarded to Bidder, who gets highest points by considering the below aspects.

| SL. No | Description   | Points                        | Total (30 Points) |
|--------|---|-------------------------------|-------------------|
| 1      | No. of years of work experience only in Educational Institutions (Government). (From 26AS must be submitted for the period of Experience claimed) | 1 point per each running year | Max. 15 points    |
| 2      | Average turnover during the last two Financial Years.   | 1 Point for each crore        | Max. 15 points    |

**Note: The Bidders must submit the hardcopies of documentary proofs for the above 2 items.**

I / we accept all the terms and conditions of the tender notice.

Date: .....

Place: .....

Name and Signature of Bidder with Seal

**6. GENERAL TERMS & CONDITIONS:**

1. The Bidders, who do not meet the eligibility criteria; or do not submit all the necessary documents in support of the eligibility criteria; or do not submit documents that are complete and valid - shall be disqualified.
2. In the event of increase in the taxes and levies implemented by the Government(s) during the contract period, the same shall be paid by Bidder.
3. Validity of prices quoted in financial bids: The validity of prices quoted in the financial bid by the Bidders is for a period of 90 days from the date of opening of the financial bid.
4. NIT Andhra Pradesh, Tadepalligudem, shall correspond only with the technically Qualified Bidders.
5. Irrespective of the offers received or their competitiveness, the final decision on choosing a Bidder, will vest in entirety with the NIT Andhra Pradesh, Tadepalligudem.
6. The Bidder is expected to examine all instructions, terms and specifications in the tender document. Failure to furnish all information required or to submit a bid not substantially responsive to the tender document in every respect will be at the Bidder's risk and may result in the rejection of the bid.
7. "Bidder must ensure to quote rate of each item. If any cell is left blank and no rate is quoted by the Bidder, rate of such item shall be treated as "0" (ZERO). However, if a tenderer quotes nil rates against each item in item rate tender or does not quote any percentage above/below on the total amount of the tender or any section/sub head in percentage rate tender, the tender shall be treated as invalid and will not be considered as lowest tenderer".
8. If any stage, it is found that any of the details/documents furnished by the Bidder is false/misleading/fabricated, his/her/its bid would be liable for cancellation without intimation to the Bidder.

Signature of the Bidder with stamp

## 7. SCOPE OF SUPPLY:

Supply & Installation of Dining tables at Students messes of NIT Andhra Pradesh, Tadepalligudem.

- SS Dining Tables 6 seated - 250 nos.

## SPECIFICATIONS:

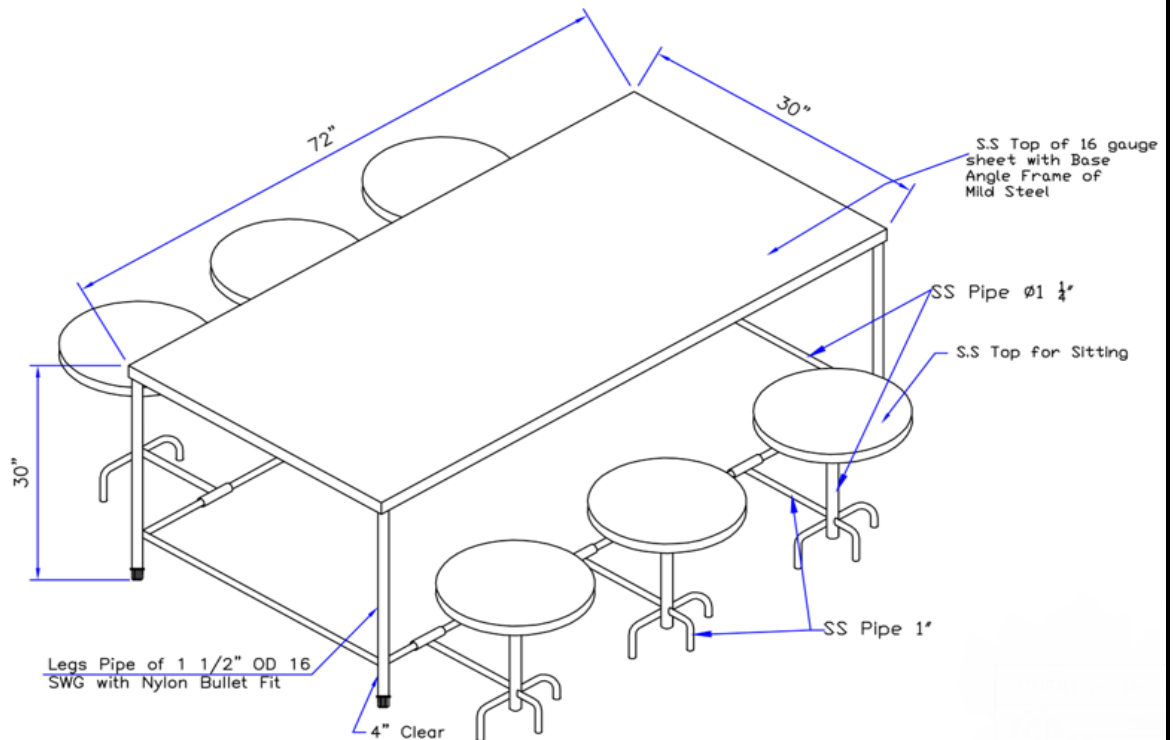

Size: 72"x30"x30"

## 8. SERVICE TERMS & CONDITIONS:

1. The vendor/contractor will be responsible for any mishap or accident during the installation /maintenance of the equipment which may occur due to negligence on part of the vendor.
2. The vendor/ contractor shall pay and be responsible for payment of all taxes, duties, levies, fees, costs or charges in respect of the products/ Equipment and services rendered to NIT Andhra Pradesh, Tadepalligudem, as part of the contract. The vendor/contractor shall indemnify and keep indemnified NIT Andhra Pradesh, Tadepalligudem, against claims in respect of above taxes, levies, duties, fees, costs, charges etc. All of the aforesaid taxes, duties, levies, fees, cost and charges shall be to the vendor/ contractor's account and NIT Andhra Pradesh, Tadepalligudem, shall not be required to pay any additional or extra amount on account of variation of the above charges if any, till the completion of work as per the contract to the satisfaction of NIT Andhra Pradesh, Tadepalligudem, and no extra claim on this account will be entertained in any case.

**9. SPECIAL TERMS & CONDITIONS:**

1. Bidders are expected to substantiate their offers by providing all necessary datasheets and testimonials of existing installations. Bids with commercial for all the items will be selected for subsequent process.
2. Rates quoted by Bidder in the Price bid is Inclusive of Supply, Installation, one-year warranty.

**10. SUPPLY AND PAYMENT SCHEDULE:**

| Phase of Supply | Duration                            | Quantity to be supplied (in nos.) | % of payment made against delivery of supply    |
|-----------------|-------------------------------------|-----------------------------------|---|
| I               | 45 days from the date of work order | Total Quantity as per Work Order  | 90% against quantity supplied as per Work Order |

**Note:**

- The retention amount shall be released only after submitting installation reports, manuals, manufacturer warranty cards, etc., to the Institute.
- TDS and other taxes/duties will be deductible as applicable as per Government of India rules.
- The Quantity may vary depending upon the Institute requirement.

**DELIVERY PERIOD:** The contractor should supply the dining tables within 45 days from the date of issue of work order.

**FOR DELAY IN SUPPLY:** Penalty of 5% of the value of the order calculated at the contract rate per week or a part of a week will be levied. The maximum penalty for late supply shall not exceed 10 % of total value of order/orders.

**ADVANCE PAYMENT:** NIT Andhra Pradesh, Tadepalligudem, will not pay any advance payment (s) against supply material or against Proforma invoice to vendor.

**WARRANTY PERIOD:** Warranty period of 1 year (Bidder will have to quote all prices with 1-year warranty) will start from the date of installation and satisfactory commissioning and acceptance. Any defects or others faults which may appear with in defect liability/warranty period of 1 year from the satisfactory working conditions or date of satisfactory report of the institute level final inspection committee whichever is later, arising in the kitchen due to material or workmanship should be corrected and replaced/repared with the parts of original specifications and makes by contractor at his own cost.

Signature of the Bidder with stamp

**ARBITRATION:** All disputes in connection with the execution of contract shall be settled under the provisions of Arbitration and Conciliation Act 1996 and the rules framed there under and in force shall be applicable to such proceedings. The Competent Authority of NIT Andhra Pradesh, Tadepalligudem, or a person nominated by him/her shall be the sole Arbitrator.

**JURISDICTION:** The Courts of Tadepalligudem alone will have jurisdiction to try any matter/dispute or reference between the parties arising out of this agreement/contract.

**COMMENCEMENT OF WORK:**

The Successful Bidder should start the work with effect from the date of commencement of agreement by mutual consent. In case, it is found that the work has not been taken up from the date of commencement of agreement, the NIT Andhra Pradesh, Tadepalligudem, at its sole discretion may cancel the work order and the Performance guarantee shall be forfeited without any further reference to the Bidder. Further, the work order will be awarded to next least quoted Bidder with the same terms and conditions.

**DISCLAIMER:**

Even though adequate care has been taken in the preparation of this Tender Schedule the Bidder should satisfy himself that the Schedule is complete in all respects.

NIT Andhra Pradesh not their employees make any representation or warranty as to the accuracy, reliability or completeness of the information in this Tender Schedule and it is not possible for the NIT Andhra Pradesh to consider the investment objective, financial situation and particular needs of each party who reads or uses the Tenders Schedule. Certain prospective Bidders may have a better knowledge of the scope of work than others. Each prospective Bidder should conduct his own investigations and analysis and check the accuracy, reliability and completeness of the information in the Tender Schedule and obtain independence advice from appropriate sources.

The Registrar, NIT Andhra Pradesh reserves the right to change any or all of the provisions of this request for Proposal. Such changes would be intimated to all parties procuring this request for Proposal.

The Registrar, NIT Andhra Pradesh reserves the right to reject any or all the Bids submitted in response to this request for Proposal at any stage without assigning any reasons whatsoever.

Signature of the Bidder with stamp

**PART-I (TECHNICAL BID)**

All the commercial conditions shall also be indicated in this part. Deviations, if any, to our specifications shall be brought out very clearly. Bidders shall mention point-wise confirmation with regard to technical specifications given in our Enquiry.

| <b>S No.</b> | <b>Particulars</b>  | <b>Details</b> |
|--------------|---|----------------|
| 1            | Bidder's name   |                |
| 2            | Registered Office and address   |                |
| 3            | Working Place of the office   |                |
| 4            | Year of Establishment   |                |
| 5            | Type of Firm (Ownership, Partnership, Pvt Ltd or Ltd Co.  |                |
| 6            | Details of ownership (Name and Address of the Board of Director, Partners etc)  |                |
| 7            | Name of the authorised signatory who is authorised to sign all the relevant documents (power of attorney, if any to be submitted) |                |
| 8            | <b>Contact Details</b>  |                |
|              | Name of the contact person  |                |
|              | Designation   |                |
|              | Telephone Number (Office)   |                |
|              | Mobile Number   |                |
|              | Email Id  |                |
| 9            | Address for communication   |                |



|    |   |                            |
|----|---|----------------------------|
|    |   |                            |
| 10 | <b>Registration Numbers:</b>  |                            |
|    | Firm Registration No.   |                            |
|    | GST No.   |                            |
| 11 | Latest ISO Certified company  | YES/NO                     |
| 12 | PAN Number  |                            |
| 13 | Total Annual Turnover for last two years  | 2017-18: Rs<br>2018-19: Rs |
| 14 | Whether Agency has been blacklisted by any Govt or Semi-Govt. organization or any other organization? If yes, provide details   | YES/NO                     |
| 15 | Do you accept all terms and conditions of tender document and signed the tender document?   | YES/NO                     |
| 16 | Do you agree to provide services as per the Institute's requirement?  | YES/NO                     |
| 17 | No. of years of service in the field of Supply & Installation of Dining tables  |                            |
| 18 | Have you submitted the details of Govt Depts, Govt Undertakings, PUSs, Public Sector Banks to whom the similar services accomplished for the last 3 years (Attach separate sheet, if necessary) | YES/NO                     |
| 19 | Have you submitted the previous work order(s), work completion certificate(s), audited accounts statement / bank statement?   | YES/NO                     |
| 20 | DD Number, Amount and Date of the EMD submitted   |                            |
| 21 | <b>Bank Particulars</b>   |                            |
|    | Account name  |                            |

|                         |  |
|-------------------------|--|
| Type of A/C: (SB/CA/CC) |  |
| A/C No.                 |  |
| IFS code                |  |
| Name of the Bank        |  |
| Branch                  |  |

**Enclose all certificates in support of above statements.**

Date:

Place:

Authorized Signatory

Name:

Designation:

Company:

Contact No.

Company Seal

### CHECKLIST

The Bidder may use the checklist below, to ensure that the tender submitted is complete in all respects.

Cover **(a) "Technical Bid"** should contain the following documents:

| S. No | Particulars   | Yes | No |
|-------|---|-----|----|
| 1     | Signed and submitted the original tender schedule downloaded from the NIT Andhra Pradesh website. |     |    |
| 2     | Crossed Demand Draft from National Bank towards Tender Processing Fee                             |     |    |
| 3     | Crossed Demand Draft from National Bank towards EMD   |     |    |
| 4     | Experience certificates   |     |    |
| 5     | Previous work orders  |     |    |
| 6     | Work satisfactory certificates  |     |    |
| 7     | Financial turnover certificates issued from competent authority                                   |     |    |
| 8     | List of present clients with address & phone numbers  |     |    |
| 9     | All documentary proofs in support of Tie breaking procedure                                       |     |    |
| 10    | Submitted latest Income Tax Saral form>Returns  |     |    |
| 11    | Copy of Firm registration certificate   |     |    |
| 12    | Copy of PAN card  |     |    |
| 13    | Copy of GST registration  |     |    |
| 14    | Signed undertaking by the Bidder/Agency (Declaration)   |     |    |

**Note:** All the pages of the original bid document may be serially numbered and signed by the Bidder.

**Signature of the Bidder with stamp**

PART II – FINANCIAL BID

1. Name of the Bidder:

**TABLE:**

| S. No.                  | Description   | Quantity required | Rate per 1 item | Total Amount quoted in Rs. |
|-------------------------|---|-------------------|-----------------|----------------------------|
| 1                       | SS Dining tables<br>6 seated<br>(as per given specifications) | 250               |                 |                            |
| 2                       | GST as applicable   |                   |                 |                            |
| TOTAL AMOUNT (in words) |   |                   |                 |                            |

Note: If there is a discrepancy between the rates quoted in words and in figures, the amount quoted in words shall prevail.

Signature

Name and Address of the Bidder with stamp

Place

Date

**PROFORMA FOR BANK GUARANTEE**

To

WHEREAS \_\_\_\_\_ ( Name of Bidder ) (hereinafter called "the Bidder " has submitted its BID dated \_\_\_\_\_ (Date) for the supply of (Name of Contract and/ or description of the goods) \_\_\_\_\_ (hereinafter called "the BID") in favour of \_\_\_\_\_ (hereinafter called the " Client ");  
KNOW ALL MEN by these presents that we, \_\_\_\_\_ Bank, having its Registered Office at \_\_\_\_\_ (address of bank) (hereinafter called "the Bank") are bound unto \_\_\_\_\_ (name of the Client) for the sum of Rs \_\_\_\_\_ (Rupees \_\_\_\_\_ only) for which payment will and truly to be made to the said Client, the Bank binds itself, its successors and assigns by these presents; Sealed with the common seal of the said Bank this \_\_\_\_\_ day of \_\_\_\_\_ 20 \_\_\_\_.

THE CONDITIONS of this obligation are:

- 1) If the Bidder withdraws its BID during the period of BID validity specified in the BID Form; or Does not accept the correction of errors in accordance with the bidding documents;
- 2) If the Bidder having been notified of the acceptance of his BID by the Client during the period of BID validity;
  - a) Fails or refuses to execute the contract, if required; or
  - b) Fails or refuses to furnish the performance Guarantee or security Deposit, in accordance with of Terms and Conditions of this BID.

We undertake to pay to the Client up to the above amount upon receipt of his first written demand without the Client having to substantiate his demand, provided that in his demand the Client will note that the amount claimed by him is due to him owing to the occurrence of one or both of the two conditions, specifying the occurred condition or conditions.

Notwithstanding anything contained herein, our liability under this Bank Guarantee shall not exceed Rs \_\_\_\_\_ (Rupees \_\_\_\_\_ only).

The Bank Guarantee is valid upto \_\_\_\_\_ and we are liable to pay the guaranteed amount or any part thereof under this Bank Guarantee only and only if you serve upon us a written claim or demand on or before \_\_\_\_\_ (mention period of the Guarantee as found under clause (ii) above plus claim period)

Dated \_\_\_\_\_ day of \_\_\_\_\_ 20 \_\_\_\_ .

**SEAL & SIGNATURE OF THE BANK**

**DECLARATION**

(To be provided on letter head of the Bidder)

I / We \_\_\_\_\_ do hereby certify that our firm is not blacklisted and no enquiries / cases are pending against us by Govt. of India / Govt. of Andhra Pradesh or by any State Board Universities, since inception of the firm / company.

All the terms and conditions given in the tender draft "**for Supply & Installation of Dining tables at student messes of NIT Andhra Pradesh Campus**" issued by NIT Andhra Pradesh, Tadepalligudem are acceptable to us.

We also certify that the information mentioned in the submitted documents is true and complete in any every respect and explicitly agree that in case at a later date it is found out by the Institute (NIT Andhra Pradesh, Tadepalligudem) that any details provided herein by us are incomplete/incorrect, any contract given to us may be summarily terminated forthwith, our firm may be blacklisted, and that the Institute may also initiate any other legal/penal proceedings, as deemed fit by it.

Date:

Place:

Authorized Signatory

Name:

Designation:

Company:

Contact No.

Company Seal:

**(ADDRESS SLIP)**

Please paste this on your envelope)

Tender No. & Date: \_\_\_\_\_  
Name of the item(s): \_\_\_\_\_  
(as mentioned in the tender)  
Due Date: \_\_\_\_\_

To,  
TENDER BOX  
C/o. Director  
National Institute of Technology Andhra Pradesh  
Near National Highway No. 16, Kondrupolu  
TADEPALLIGUDEM – 534101  
West Godavari District, Andhra Pradesh

From: \_\_\_\_\_  
\_\_\_\_\_  
\_\_\_\_\_